

Mechanical design of the HRS and Impact of the nuclearization on this design

Building and beam lines SPIRAL2 - Phase 2

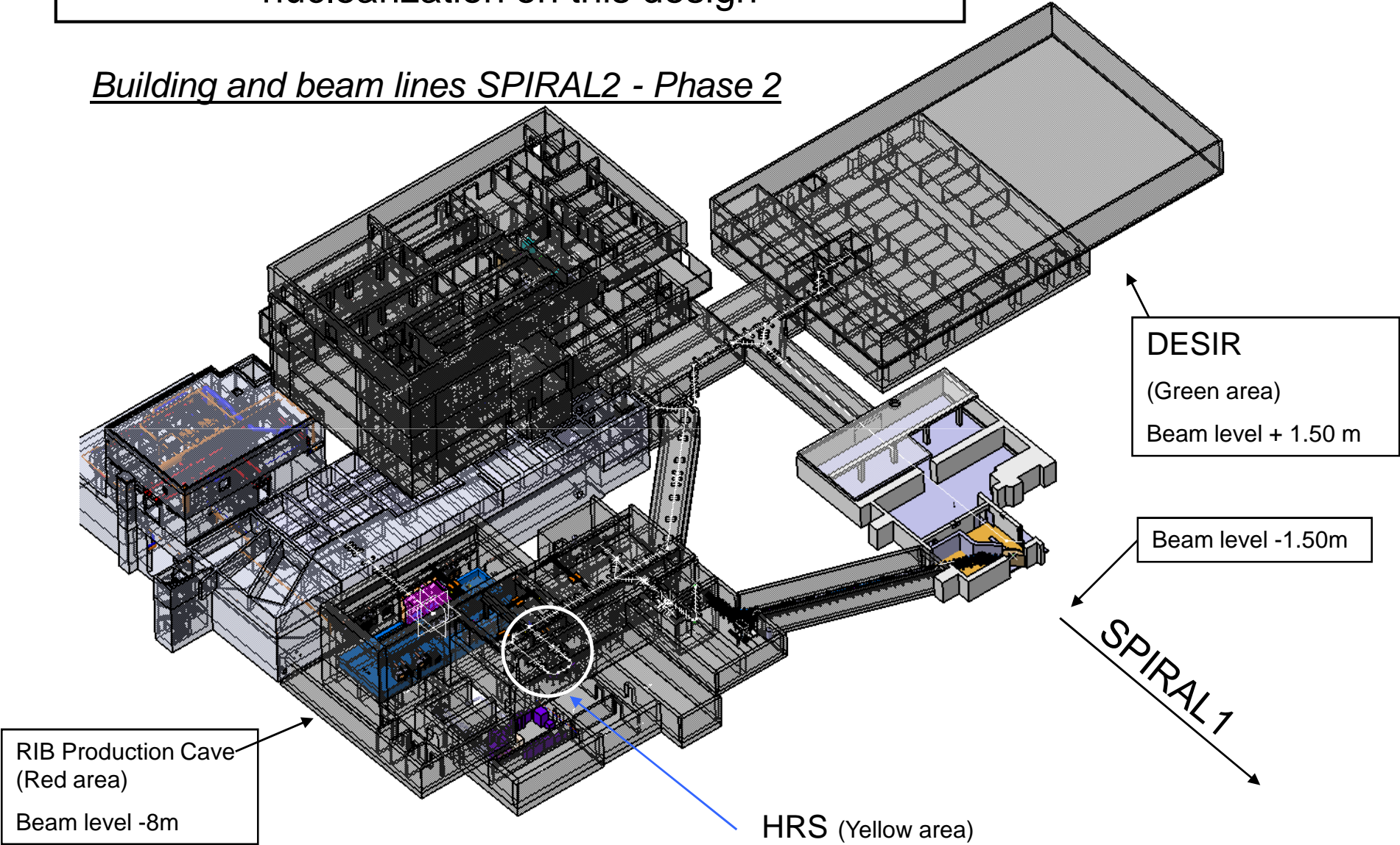

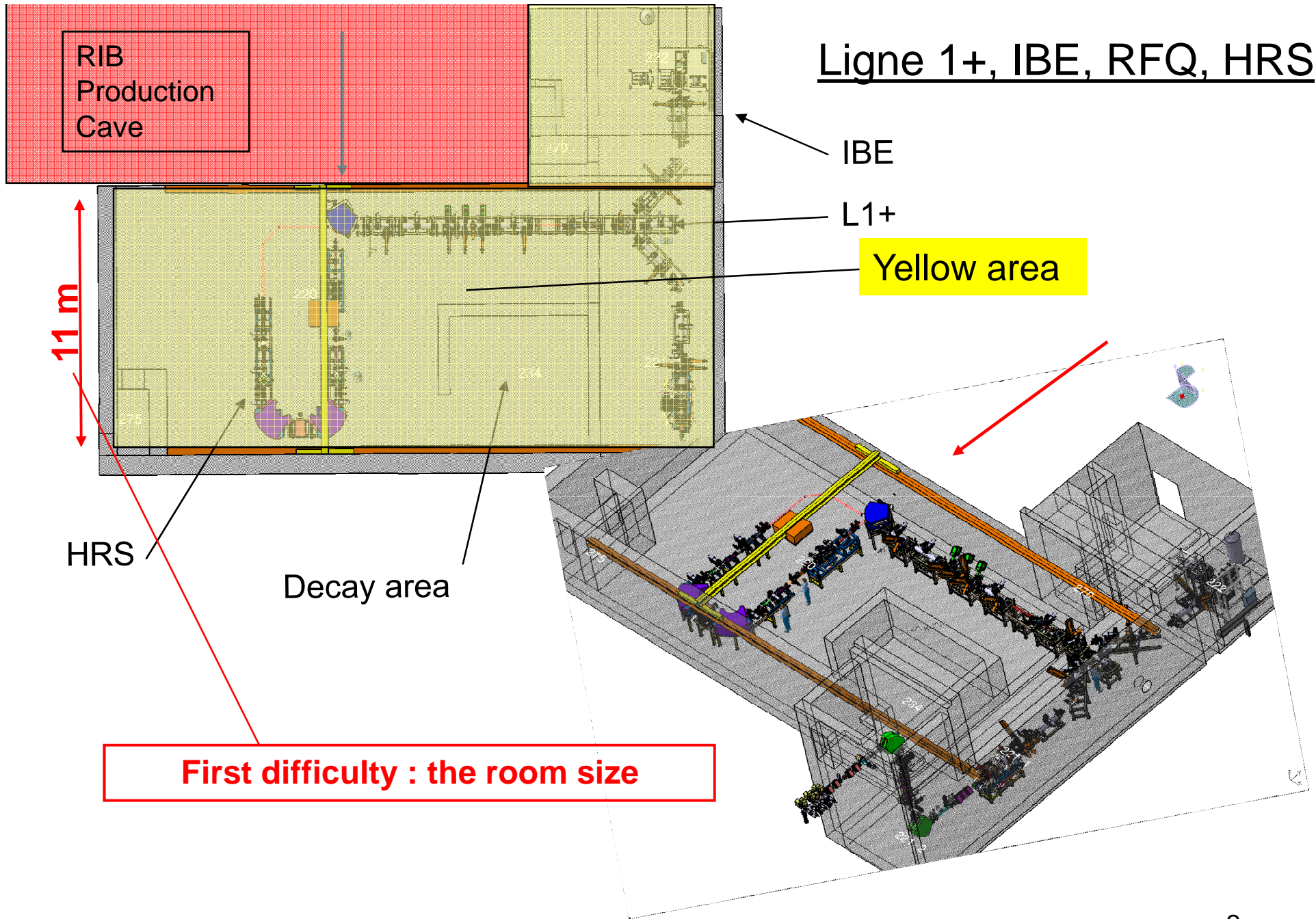

HRS Optic Skeleton

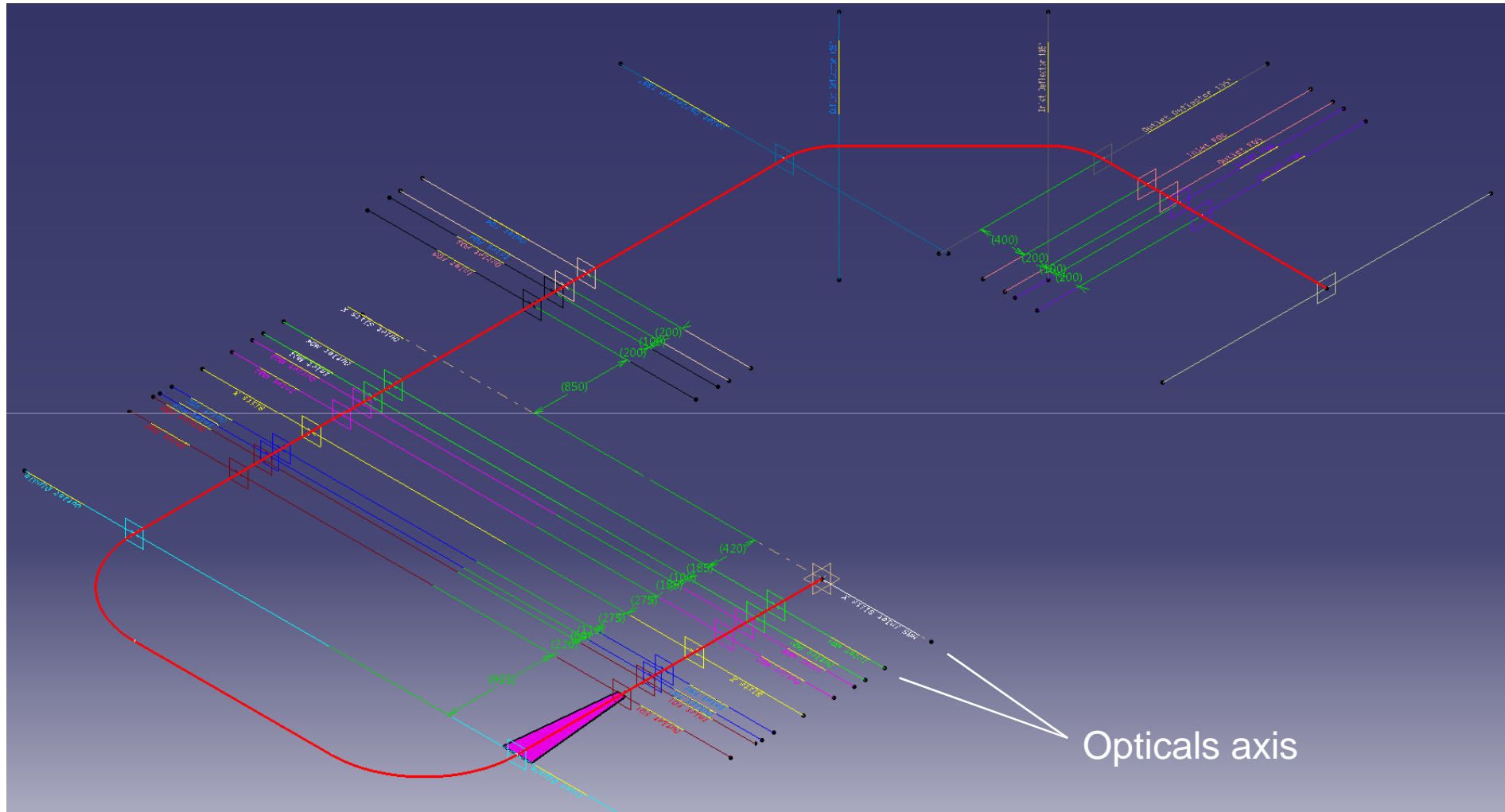

Division into modules

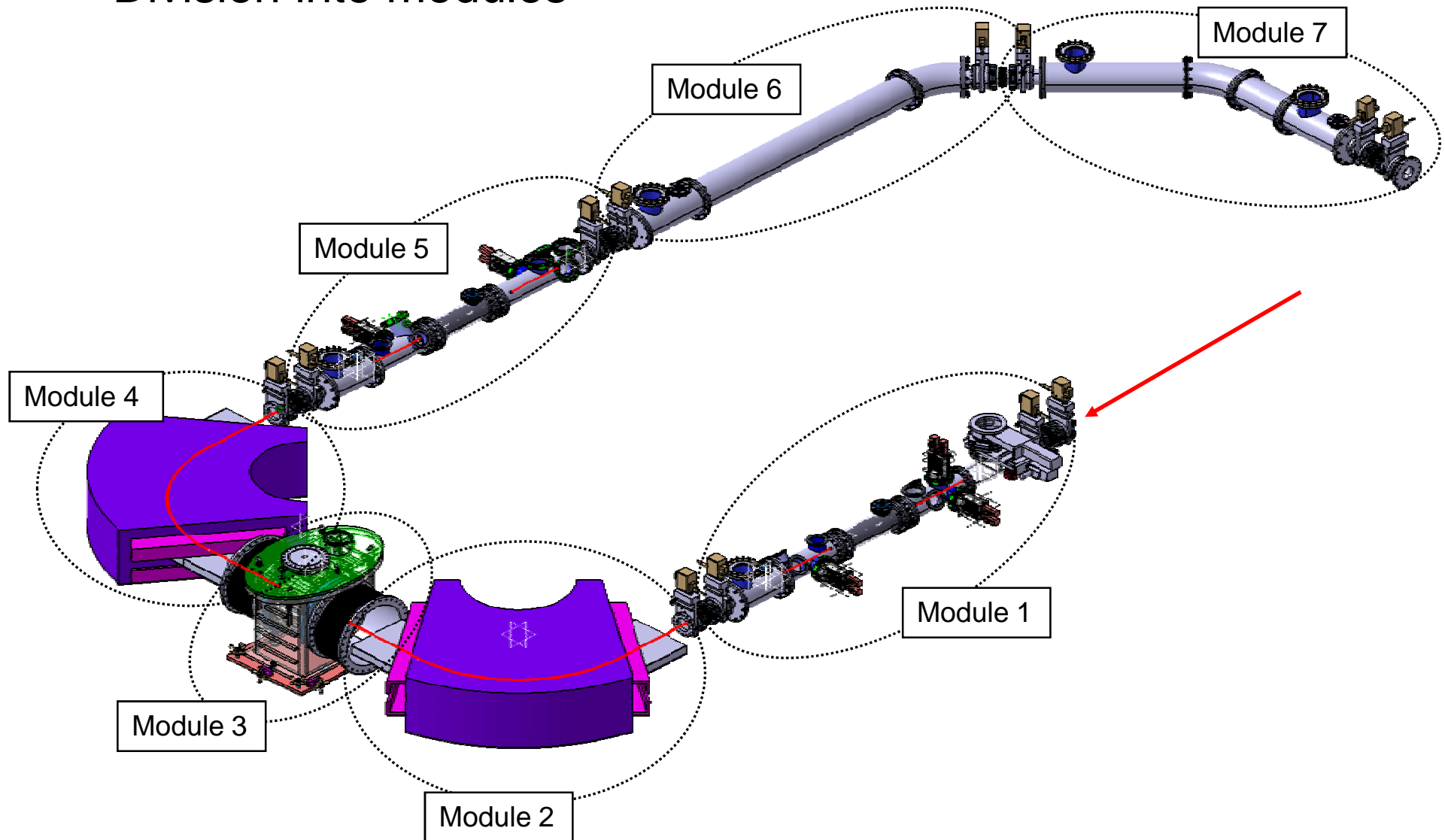

Global 3D view of the HRS

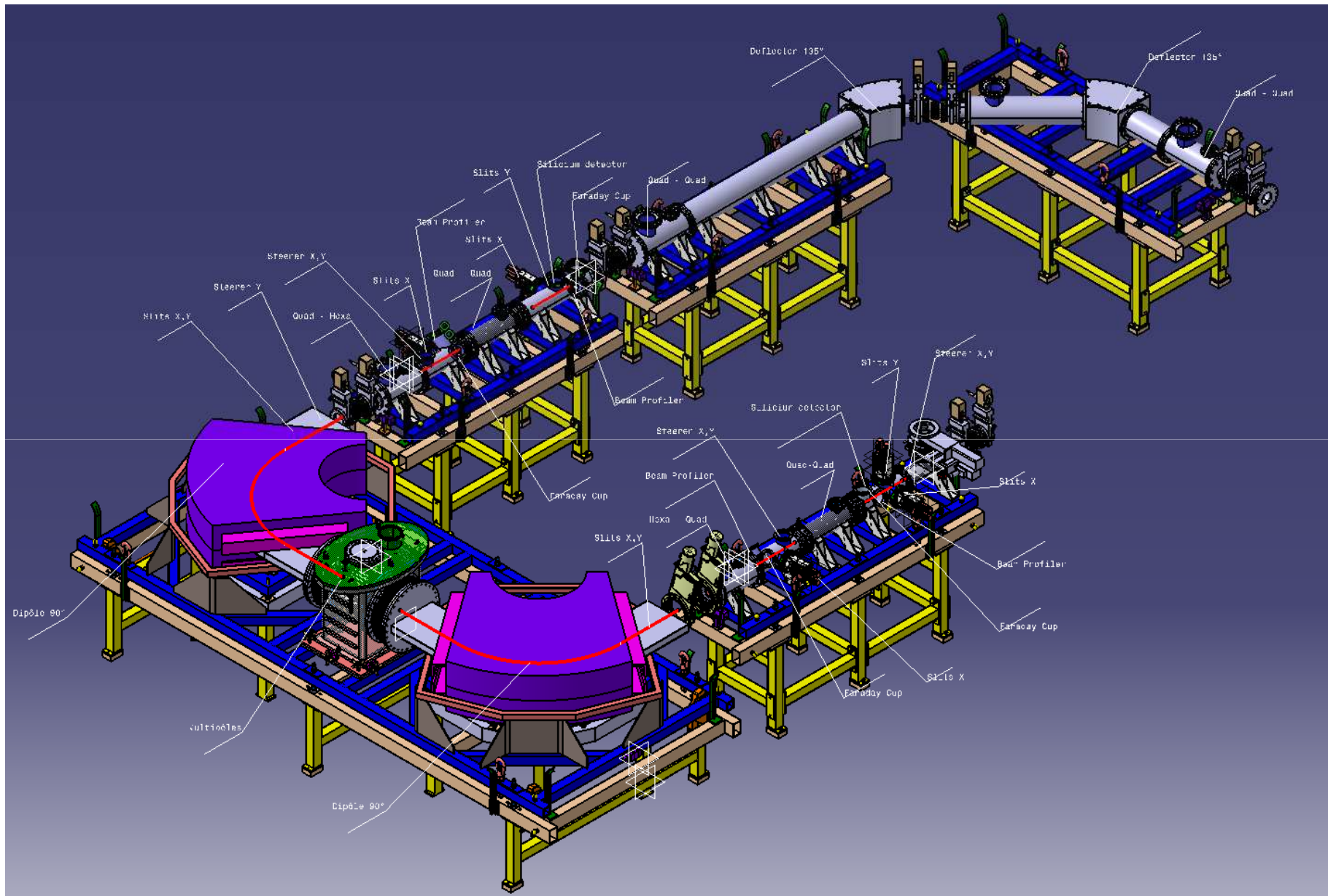

2D View

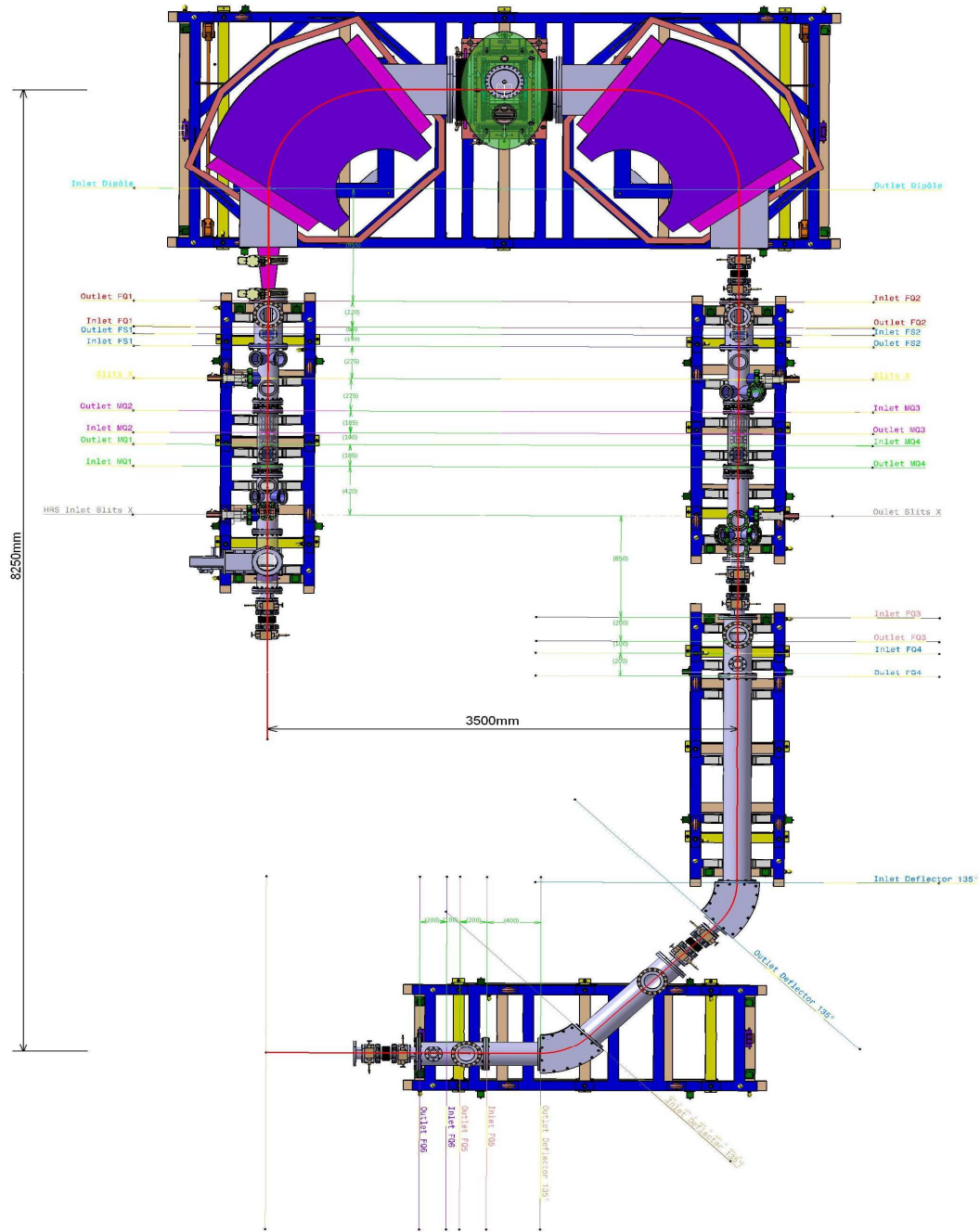

Principle of maintenance modules

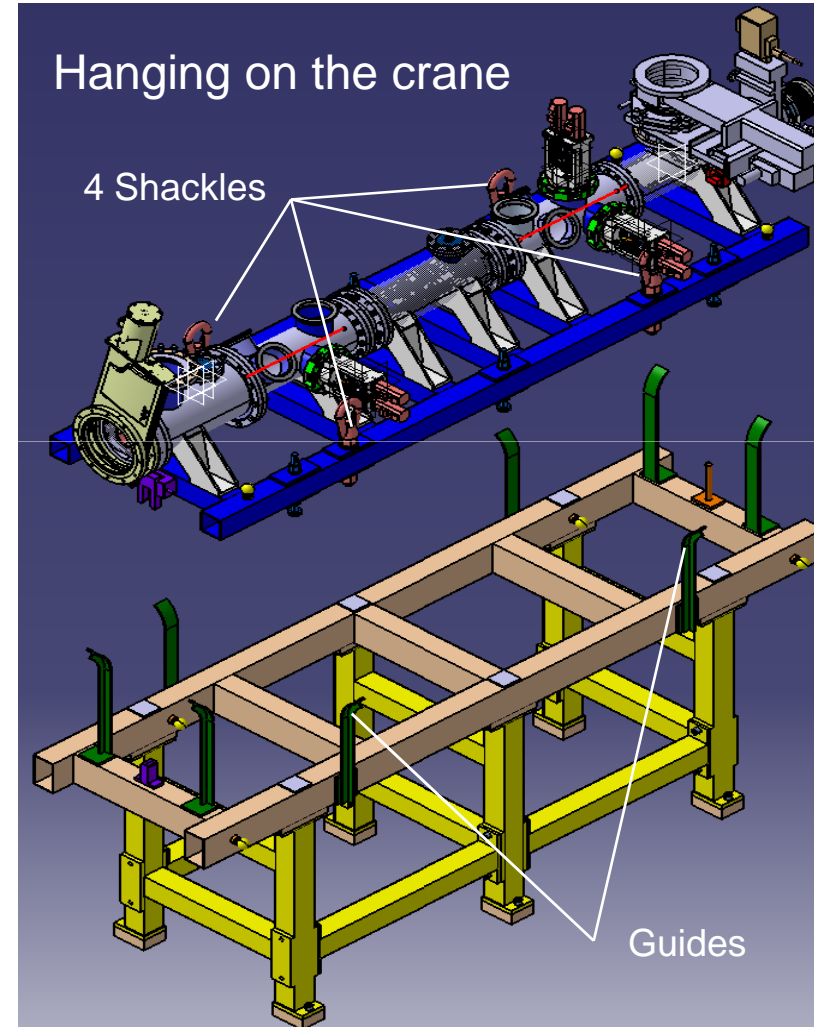
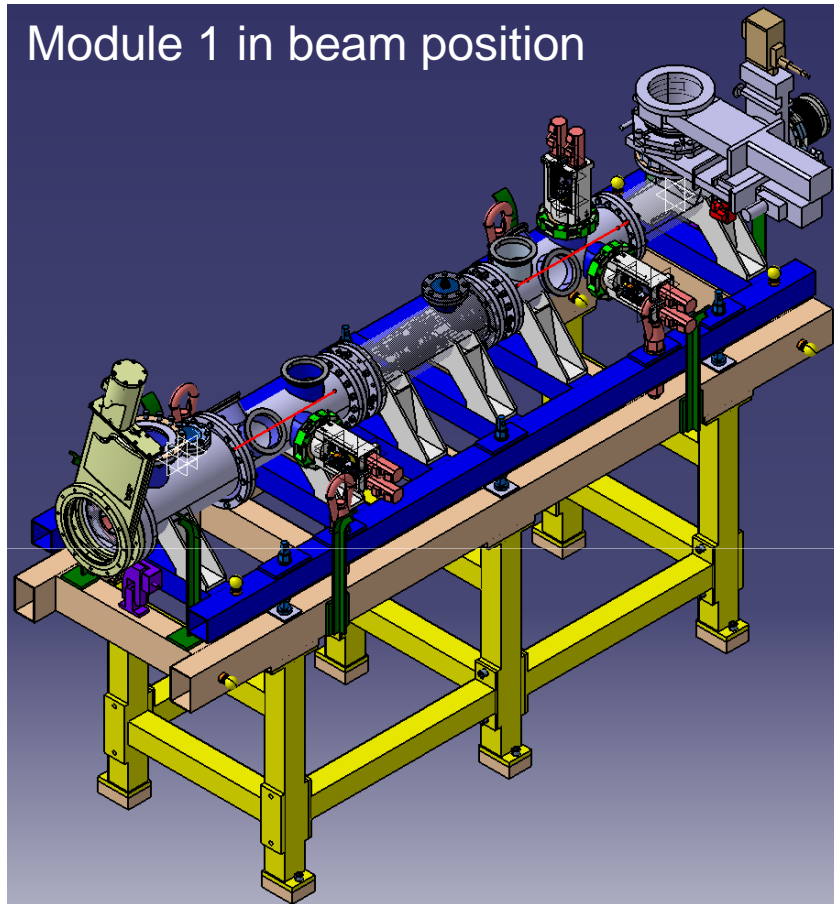

System of motorized slits

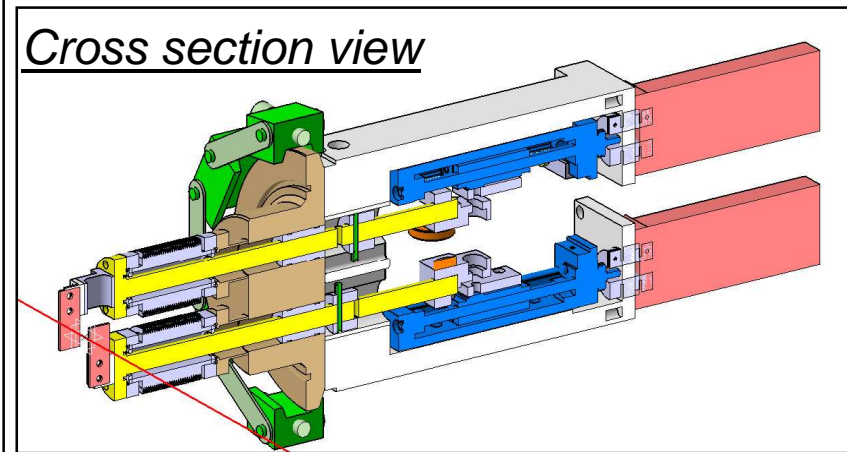
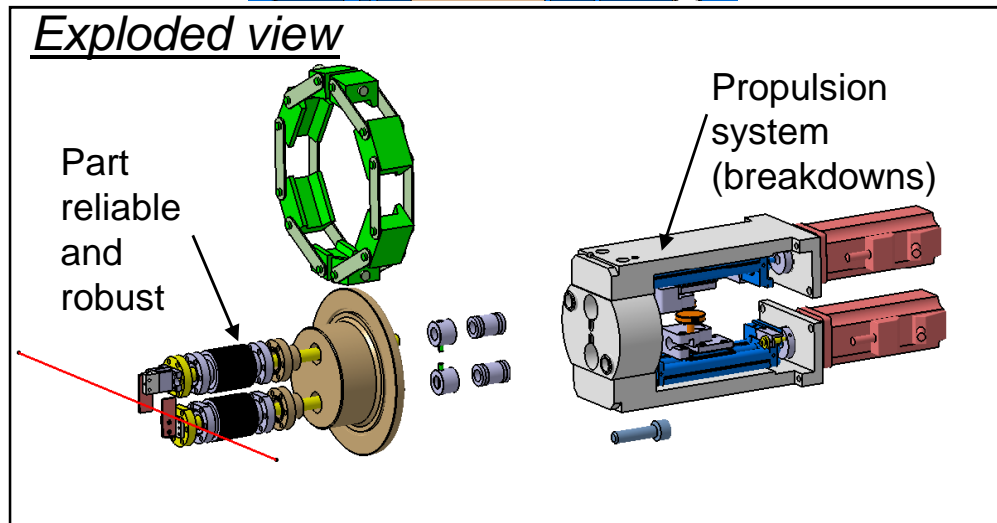
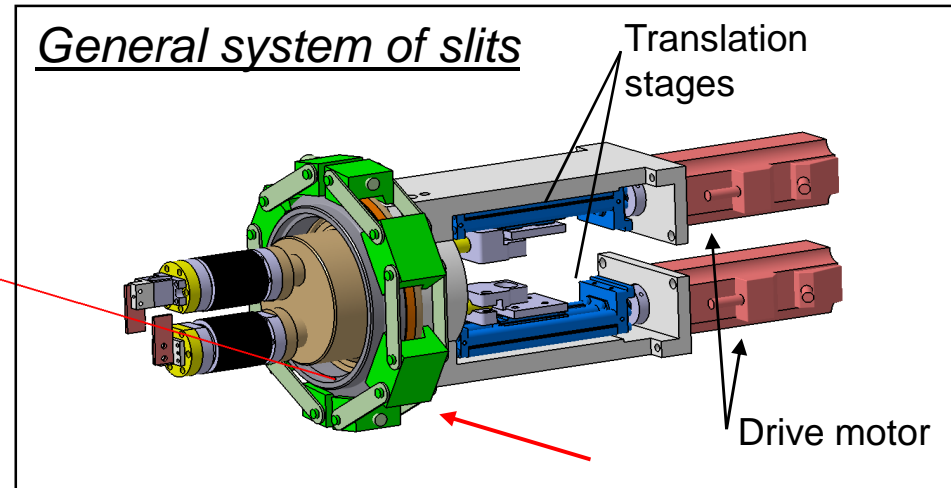
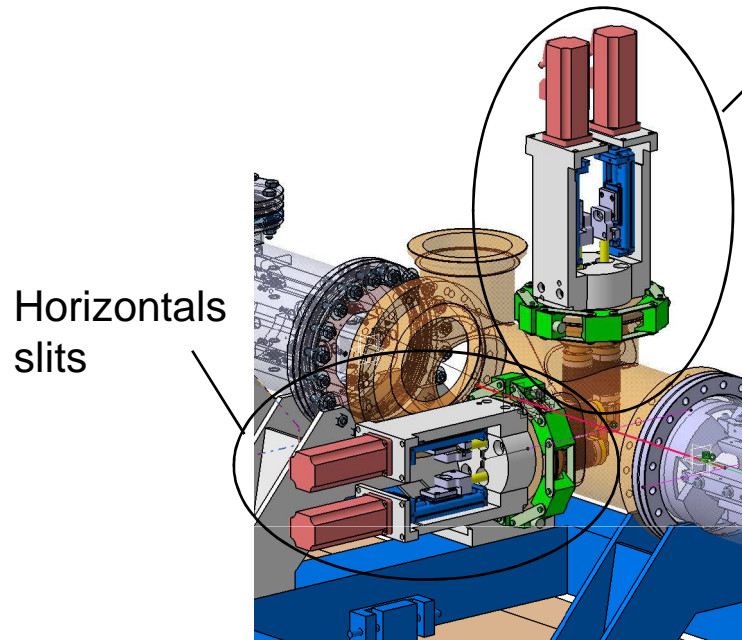

Disassembly of the propulsion system

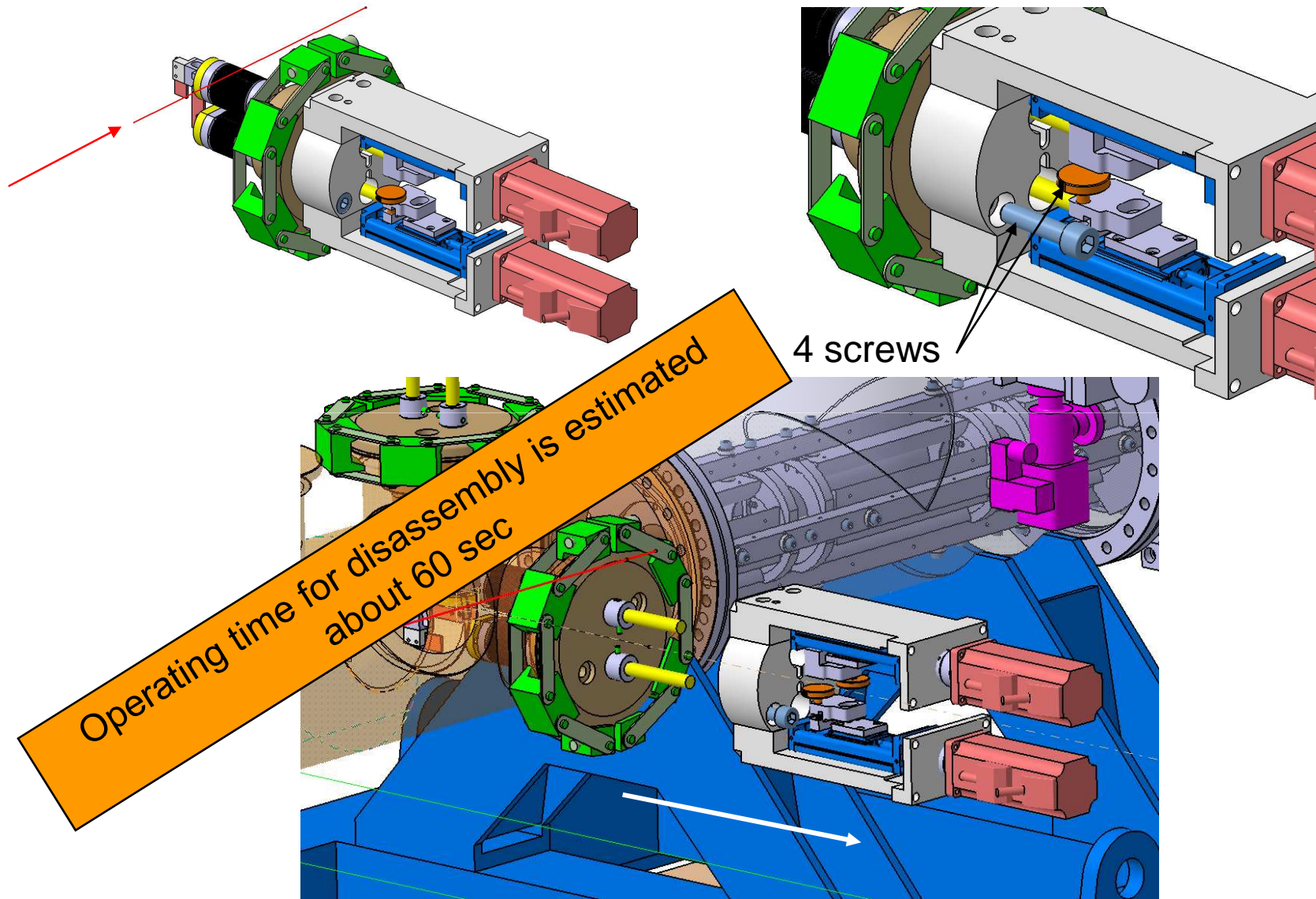

Assembly of the propulsion system

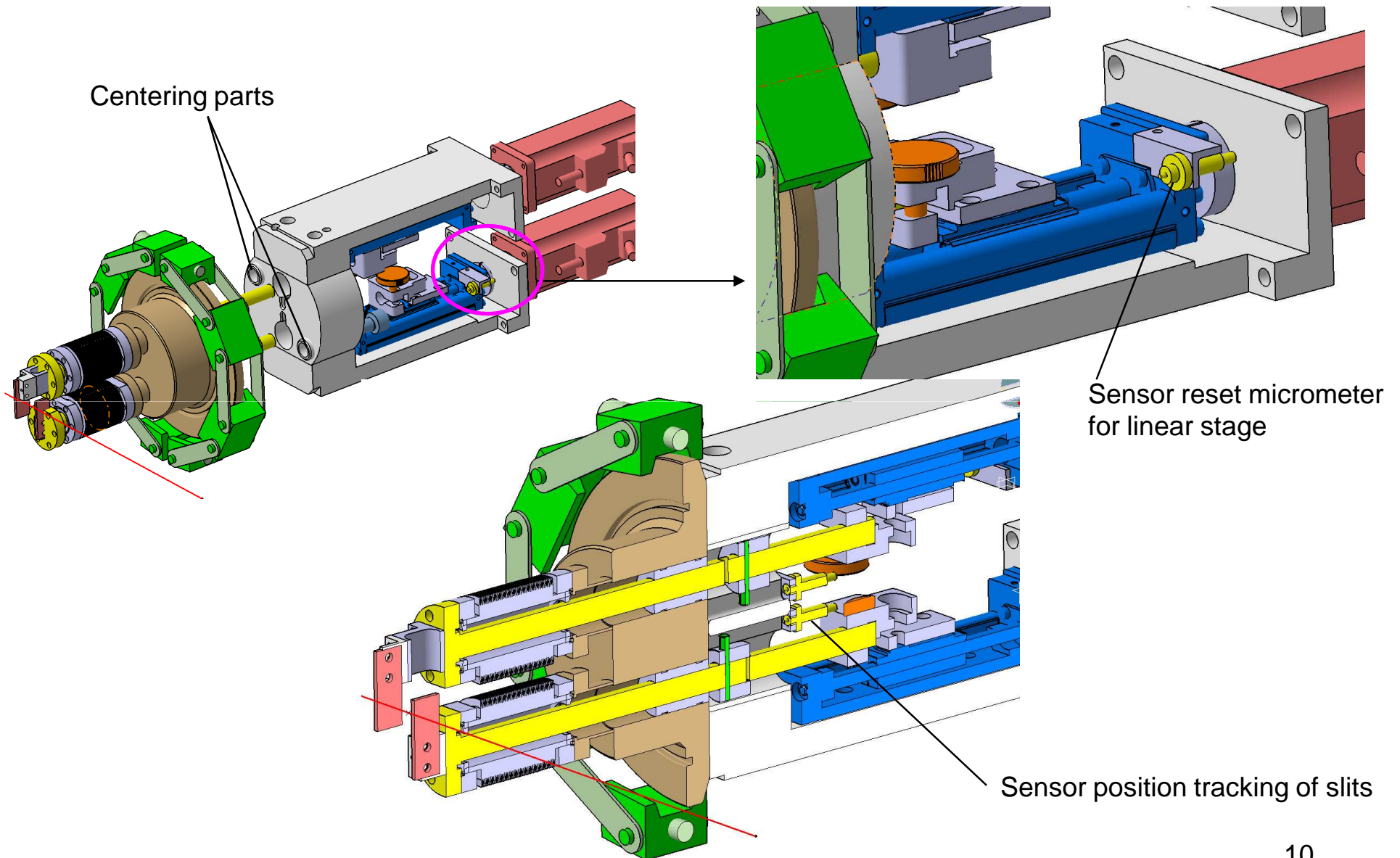

Maintenance of electrostatics pôles

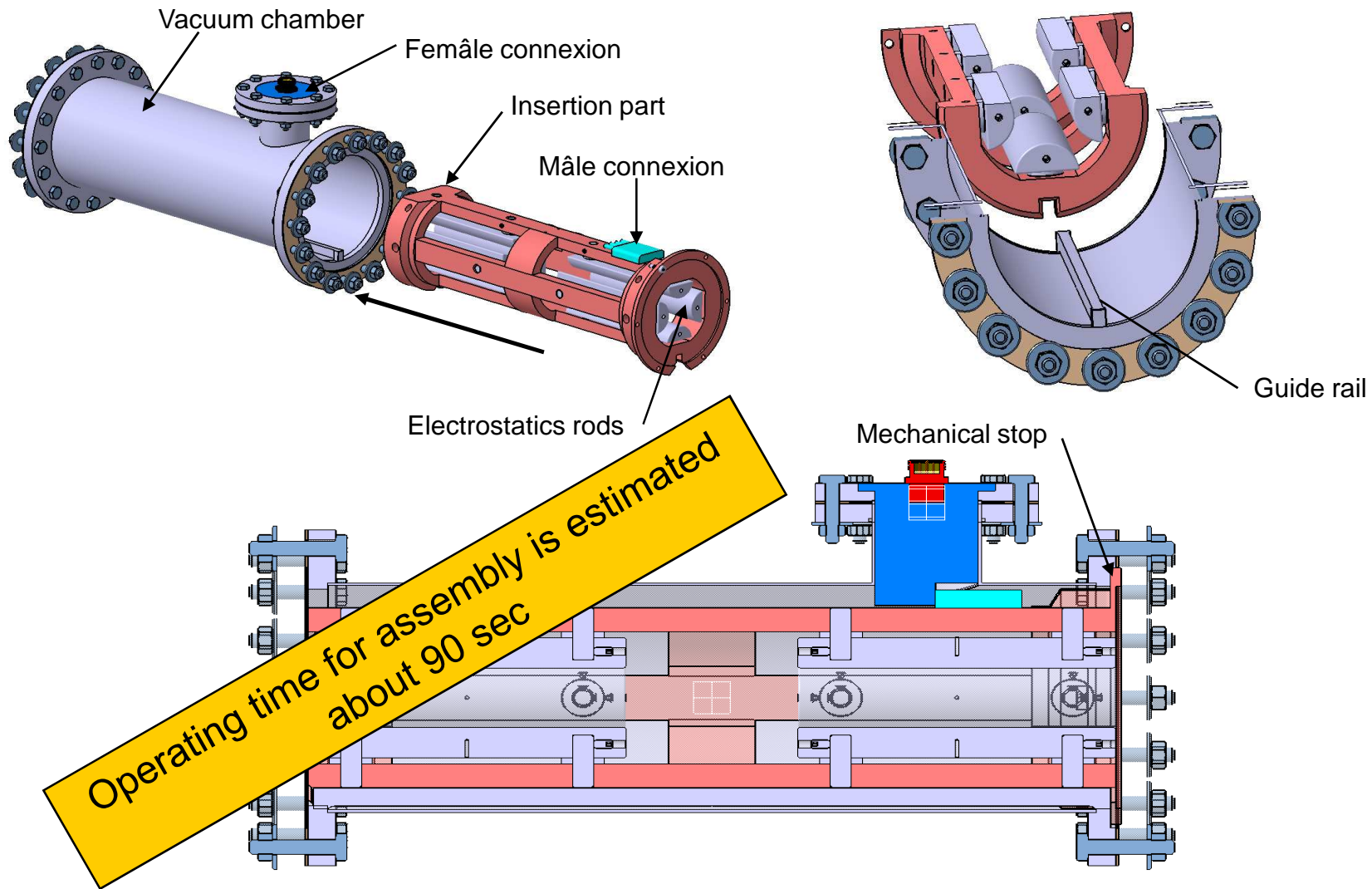

Thanks to Thierry and Thomas...

View on
CATIA
3D CAO models !